



Beta Three

CS3415A

THEATER MAIN SPEAKER

USER'S MANUAL

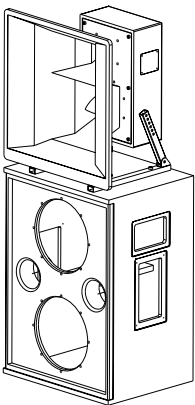

ED-B3-MA-051112-002



Features:

■ **Four transducers three way phase-inversed surrounding cinema speaker, professional high efficient transducers. Computer simulating design.**

- Four transducers three way full range
- High SPL, high sensitivity
- Two 15" big power woofers
- One 10" compression horn mid range transducer,
- One compression driver with 75mm titanium diaphragm
- Built-in crossover for HF/MF. external crossover for MF/HF
- 90° × 40° wide dispersion can get the wider covering
- Computer simulating design provide very good Frequency response and phase feature
- Very convenient walling installation mode
- Suitable for THX,DTS and other multi-channel surrounding sound reinforcement in cinema
- Suitable for big/mid cinema audio system
- Combining with β 3 special speaker controller Σ C-2600 can get good frequency response and phase
- Can work with β 3 CSB218A, CSR210A, CSR212A, CSR215A when used for high quality music replaying



Specifications:

| | |
|--------------------------------|---|
| Transducers | Bass: 15"×2; Mid: 10"×1; Treb: φ 75mm×1 |
| Frequency response(-3dB/-10dB) | LOW:35Hz-550Hz/29Hz-700Hz, MID/HIGH:400Hz-15KHz/300Hz-20KHz |
| Sensitivity(1m/1W) | LOW:102dB, MID/HIGH:105dB |
| Xover point | LOW/MID:300Hz, MID/HIGH:1.7KHz |
| Dispersion(H×V) | 90° × 40° |
| Power(RMS) | LOW:900W, MID/HIGH:300W |
| Rated impedance | LOW:4 Ohm, MID/HIGH:8 Ohm |
| DC impedance | LOW:2.8 Ohm, MID/HIGH:6.2 Ohm |
| THD | <3% |
| Input | Spring clip |
| Net weight | LOW:76Kg, MID/HIGH:32.5Kg |
| Gross weight | LOW:82Kg, MID/HIGH:37Kg |
| Dimensions(W×D×H) | LOW:700×600×1000mm, MID/HIGH:700×508×731mm |
| Packing dimensions(W×D×H) | LOW:810×660×1120mm, MID/HIGH:845×816×638mm |

Cabinet Dimension:

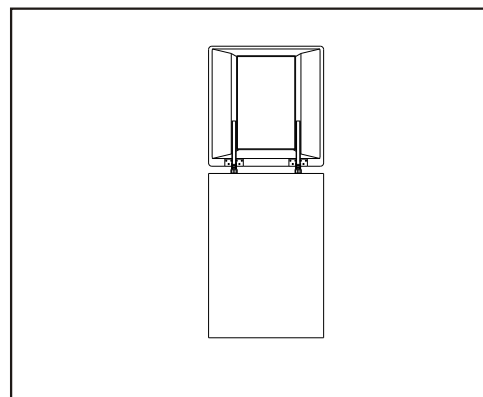
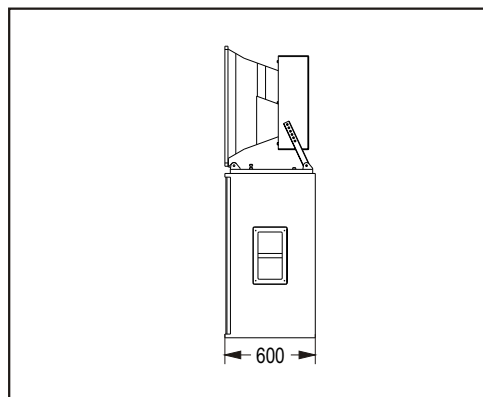
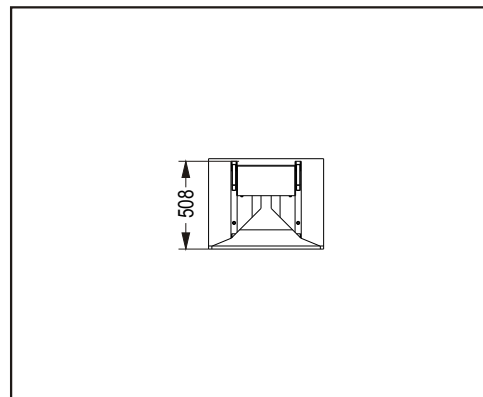
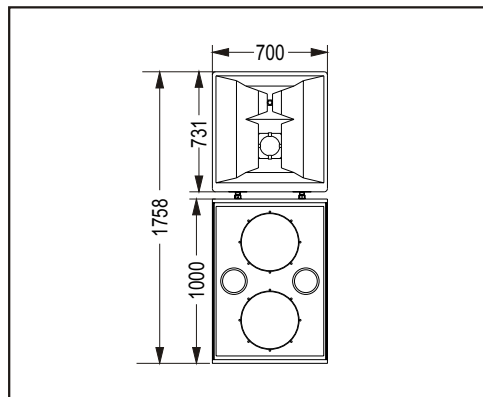

Installation drawing:

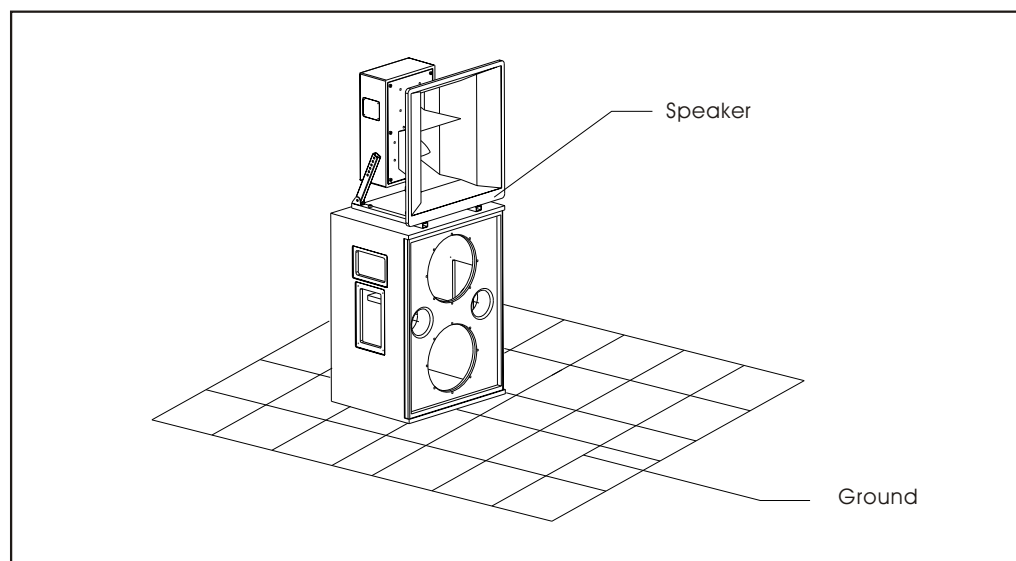

CS3415A
THEATER MAIN SPEAKER